



www.GlomacAmerica.com



Slurry Champ

100 XP

HEAVY DUTY HYDRAULIC SUBMERSIBLE SLURRY PUMP

NUMBER ONE FOR RELIABILITY, STRENGTH & ENDURANCE

100mm heavy duty pump with a replaceable casing and drainless motor suitable for use as an excavator attachment. For use with an excavator rated at 10-25t.

- Single piece cast iron body to enhance rigidity and reduce wear
- Bearings run in oil bath for lubrication and cooling
- Twin volute casing design to reduce rotational imbalance and increase lifetime of bearings and seals
- Rotating inducer creates hydrodynamic shock waves to re-suspend settled particles beneath the pump inlet
- Single stage, open vane impeller
- Precision bearings
- Non pressurised mechanical seal
- Bent axis swash plate piston motor without case drain

1

Add to Cart

DIMENSIONS

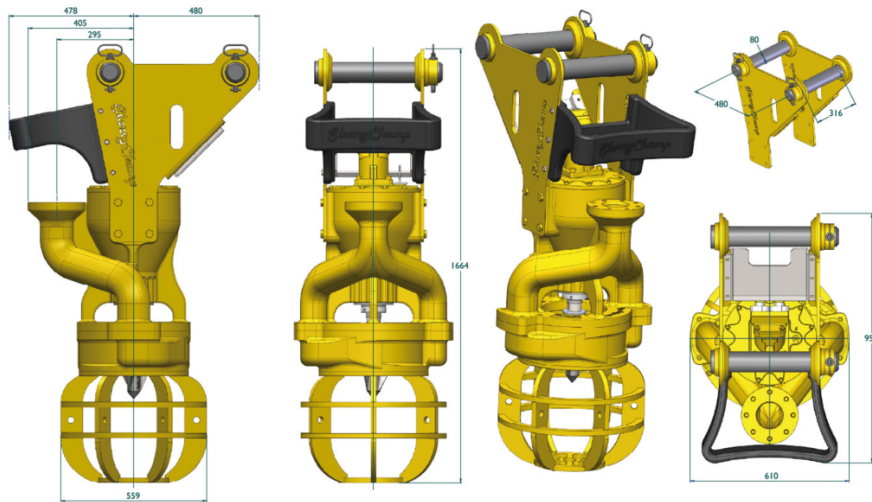

Note: Alternative lifting pin configuration are available to suit excavators.



(Fits 100mm PN16)  
M16\*2.0P- 8 Places  
ø179mm PCD



www.GlomacAmerica.com



## PUMP DATA

Design fluid handled	Slurry
Maximum fluid SG	2.0 kg/l
Maximum fluid solids content	55% by weight
Maximum particle size	32 mm
Weight	525 kg
Maximum fluid temperature	90 °C
Recommended pH range	4-10
Outlet diameter	100 mm
Maximum flow	230 m <sup>3</sup> /hr @ 1500rpm
Maximum head	51 m (5.0 bar) @ 1800rpm
Impeller diameter	320 mm
Impeller tip speed	24 m/s @ 1800rpm
Peak efficiency	62 %
Maximum submergence depth*	28 m
Motor displacement	63cc
Speed range	1200 - 1800rpm

## OTHER DATA

Hydraulic service live ports	SAE J518 Code 62 3/4 inch (6000psi)		
Allowable hydraulic pressure	250 bar		
Hydraulic service drain port	3/4 inch - 16UNF-2B		
Required hydraulic oil supply	RPM	Water	Slurry SG 2.0 Kg/l
	1200rpm	73 Litres per minute @ 65 bar	73 Litres per minute @ 130 bar
	1500rpm	93 Litres per minute @ 98 bar	93 Litres per minute @ 196 bar
	1800rpm	108 Litres per minute @ 125 bar	108 Litres per minute @ 250 bar

\*As standard, can be deeper if required.

## PUMP CURVE

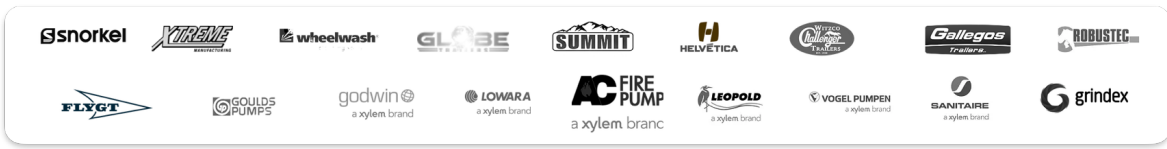
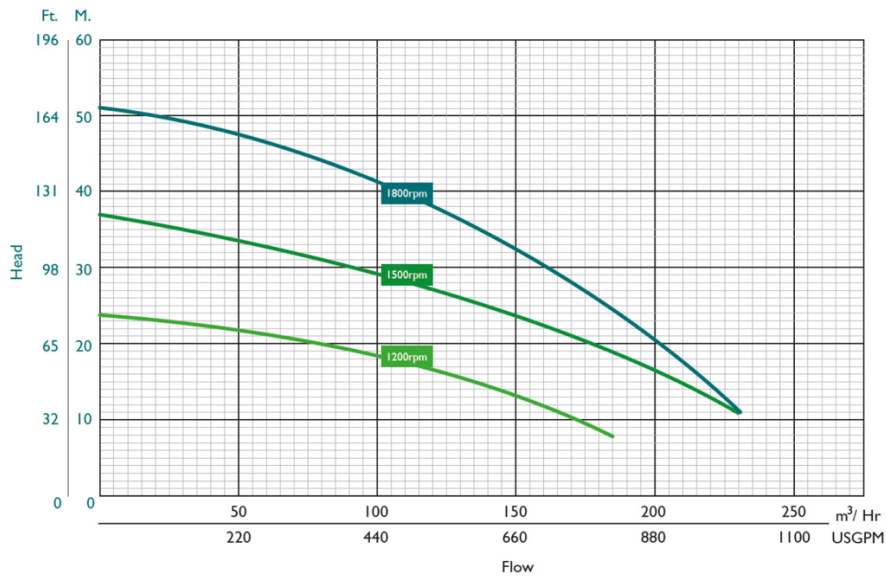



www.GlomacAmerica.com



*Slurry Champ*

# 100 XPL

## LIGHT DUTY HYDRAULIC SUBMERSIBLE SLURRY PUMP

NUMBER ONE FOR RELIABILITY, STRENGTH & ENDURANCE

100mm pump for light duty with a drainless motor suitable for use as an excavator attachment. For use with an excavator rated at 10-25t.

- Single piece cast iron body to enhance rigidity and reduce wear
- Bearings run in oil bath for lubrication and cooling
- Twin volute casing design to reduce rotational imbalance and increase lifetime of bearings and seals
- Rotating inducer creates hydrodynamic shock waves to re-suspend settled particles beneath the pump inlet
- Single stage, open vane impeller
- Precision bearings
- Non pressurised mechanical seal
- Bent axis swash plate piston motor without case drain

10

Add to Cart

### DIMENSIONS

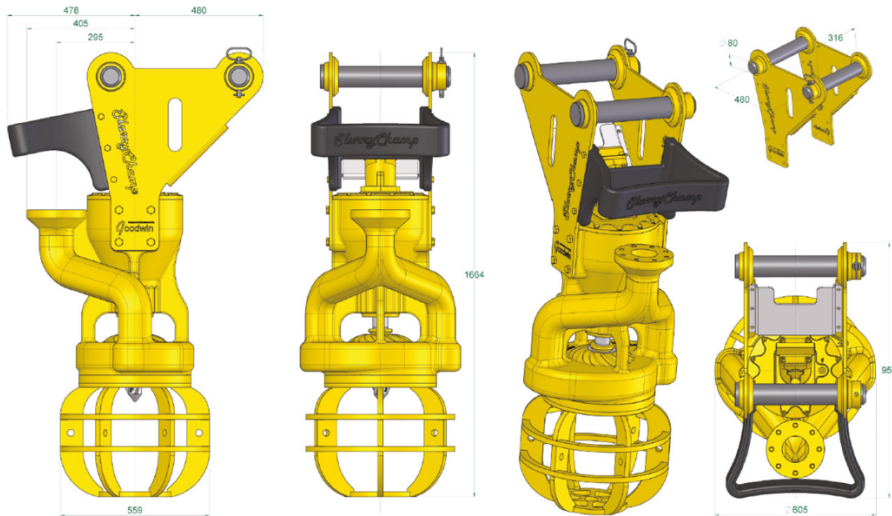

Note: Alternative lifting pin configuration are available to suit excavators.



(Fits 100mm PN16)  
M16\*2.0P- 8 Places  
ø179mm PCD

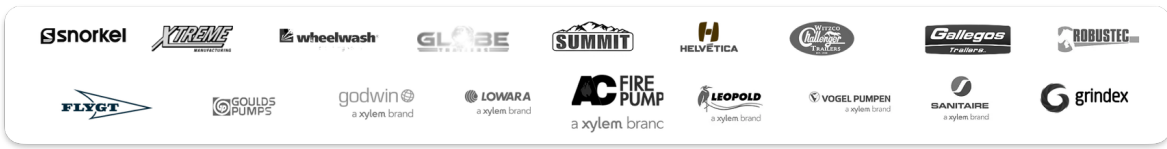

www.GlomacAmerica.com



## PUMP DATA

Design fluid handled	Slurry
Maximum fluid SG	2.0 kg/l
Maximum fluid solids content	55 % by weight
Maximum particle size	32 mm
Maximum fluid temperature	90 °C
Recommended pH range	4-10
Weight	500 kg
Outlet diameter	100 mm
Maximum flow	230 m <sup>3</sup> /hr @ 1500rpm
Maximum head	51m (5.0 bar) @ 1800rpm
Impeller diameter	320 mm
Impeller tip speed	24 m/s @ 1800rpm
Peak efficiency	62%
Maximum submergence depth*	28 m
Motor displacement	63cc
Speed range	1200 - 1800rpm

## OTHER DATA

Hydraulic service live ports	SAE J518 Code 62 3/4 inch (6000psi)		
Allowable hydraulic pressure	250 bar		
Hydraulic service drain port	3/4 inch - 16UNF-2B		
Required hydraulic oil supply	RPM	Water	Slurry SG 2.0 Kg/l
	1200rpm	73 Litres per minute @ 65 bar	73 Litres per minute @ 130 bar
	1500rpm	93 Litres per minute @ 98 bar	93 Litres per minute @ 196 bar
	1800rpm	108 Litres per minute @ 125 bar	108 Litres per minute @ 250 bar

\*As standard, can be deeper if required.

## PUMP CURVE

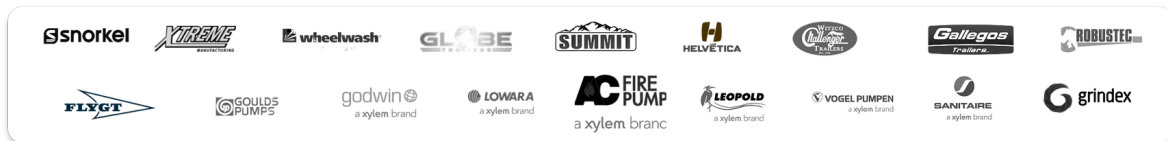
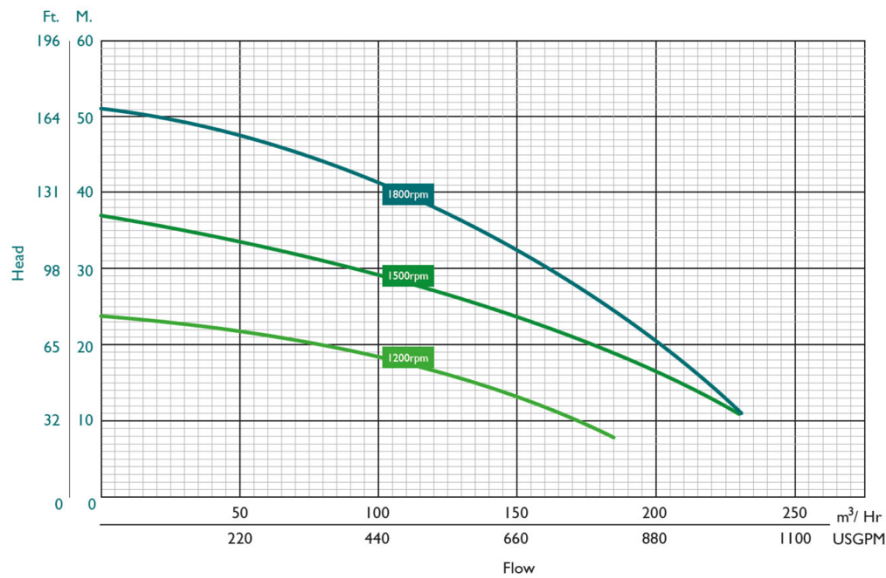



www.GlomacAmerica.com

## Slurry Champ 100 XPSC

NUMBER ONE FOR RELIABILITY, STRENGTH & ENDURANCE

100mm heavy duty pump with a replaceable casing and side cutters, suitable for use as an excavator attachment. For pumping heavily settled solids. For use with an excavator rated at 15-30t.

1

Add to Cart



www.GlomacAmerica.com



www.GlomacAmerica.com



*Slurry Champ*

**100**

**HEAVY DUTY HYDRAULIC SUBMERSIBLE SLURRY PUMP**

**NUMBER ONE FOR RELIABILITY, STRENGTH & ENDURANCE**

100mm heavy duty pump with a replaceable casing suitable for use in a traditional suspended installation.

- Single piece cast iron body to enhance rigidity and reduce wear
- Bearings run in oil bath for lubrication and cooling
- Twin volute casing design to reduce rotational imbalance and increase lifetime of bearings and seals
- Rotating inducer creates hydrodynamic shock waves to re-suspend settled particles beneath the pump inlet
- Replaceable wet end components made from carefully chosen wear resistant alloys to create a heavy duty, long lifetime wet end
- Single stage, open vane impeller
- Precision bearings
- Non pressurised mechanical seal
- Bent axis swash plate piston motor available in drainless or heavy duty (with case drain) configurations

1

Add to Cart

**DIMENSIONS**

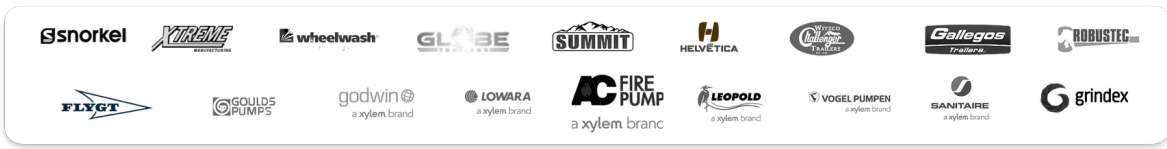
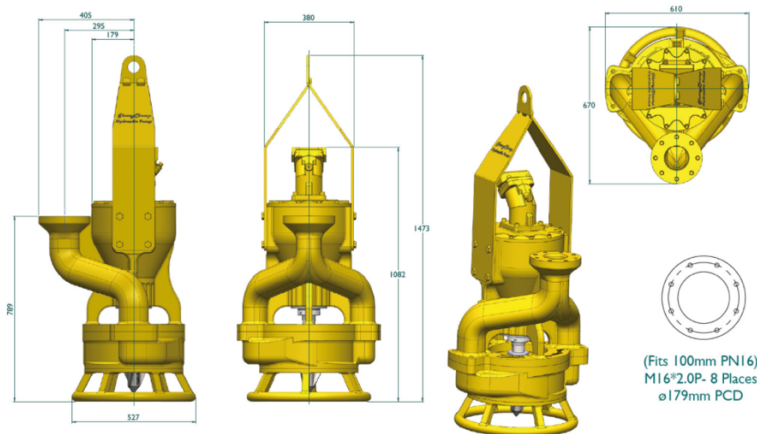

www.GlomacAmerica.com





www.GlomacAmerica.com



*Slurry Champ*

**100 L**

**LIGHT DUTY HYDRAULIC SUBMERSIBLE SLURRY PUMP**

**NUMBER ONE FOR RELIABILITY, STRENGTH & ENDURANCE**

100mm light duty pump suitable for use in a traditional suspended installation.

- Single piece cast iron body to enhance rigidity and reduce wear
- Bearings run in oil bath for lubrication and cooling
- Twin volute casing design to reduce rotational imbalance and increase lifetime of bearings and seals
- Rotating inducer creates hydrodynamic shock waves to re-suspend settled particles beneath the pump inlet
- Single stage, open vane impeller
- Precision bearings
- Non pressurised mechanical seal
- Bent axis swash plate piston motor available in drainless or heavy duty (with case drain) configurations

1

Add to Cart

**DIMENSIONS**

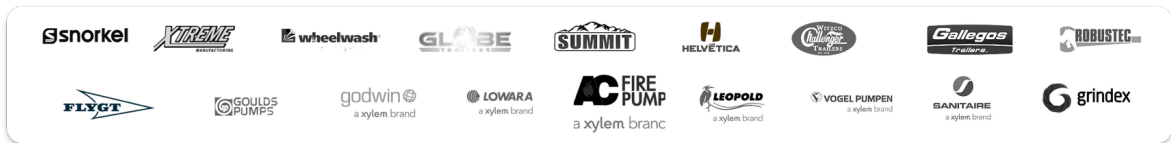
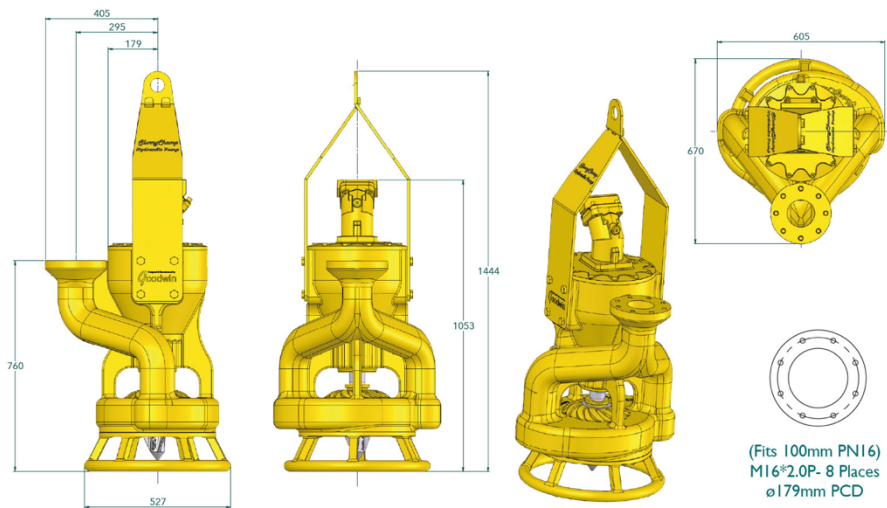

www.GlomacAmerica.com



## PUMP DATA

Design fluid handled	Slurry
Maximum fluid SG	2.0 kg/l
Maximum fluid solids content	55 % by weight
Maximum particle size	32 mm
Maximum fluid temperature	90 °C
Recommended pH range	4-10
Weight	375 kg
Outlet diameter	100 mm
Maximum flow	230 m <sup>3</sup> /hr @ 1500rpm
Maximum head	51m (5.0 bar) @ 1800rpm
Impeller diameter	320 mm
Impeller tip speed	24 m/s @ 1800rpm
Peak efficiency	62%
Maximum submergence depth*	28 m
Motor displacement	63cc
Speed range	1200 - 1800rpm

## OTHER DATA

Hydraulic service live ports	SAE J518 Code 62 3/4 inch (6000psi)		
Allowable hydraulic pressure	250 bar		
Hydraulic service drain port	3/4 inch – 16UNF-2B		
Required hydraulic oil supply	RPM	Water	Slurry SG 2.0 Kg/l
	1200rpm	73 Litres per minute @ 65 bar	73 Litres per minute @ 130 bar
	1500rpm	93 Litres per minute @ 98 bar	93 Litres per minute @ 196 bar
	1800rpm	108 Litres per minute @ 125 bar	108 Litres per minute @ 250 bar

\*As standard, can be deeper if required.

## PUMP CURVE

